

ELEVATED DECK STRUCTURE

PLAN

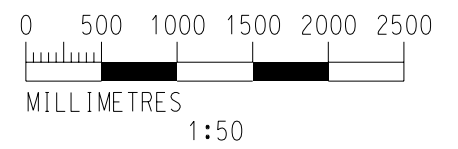
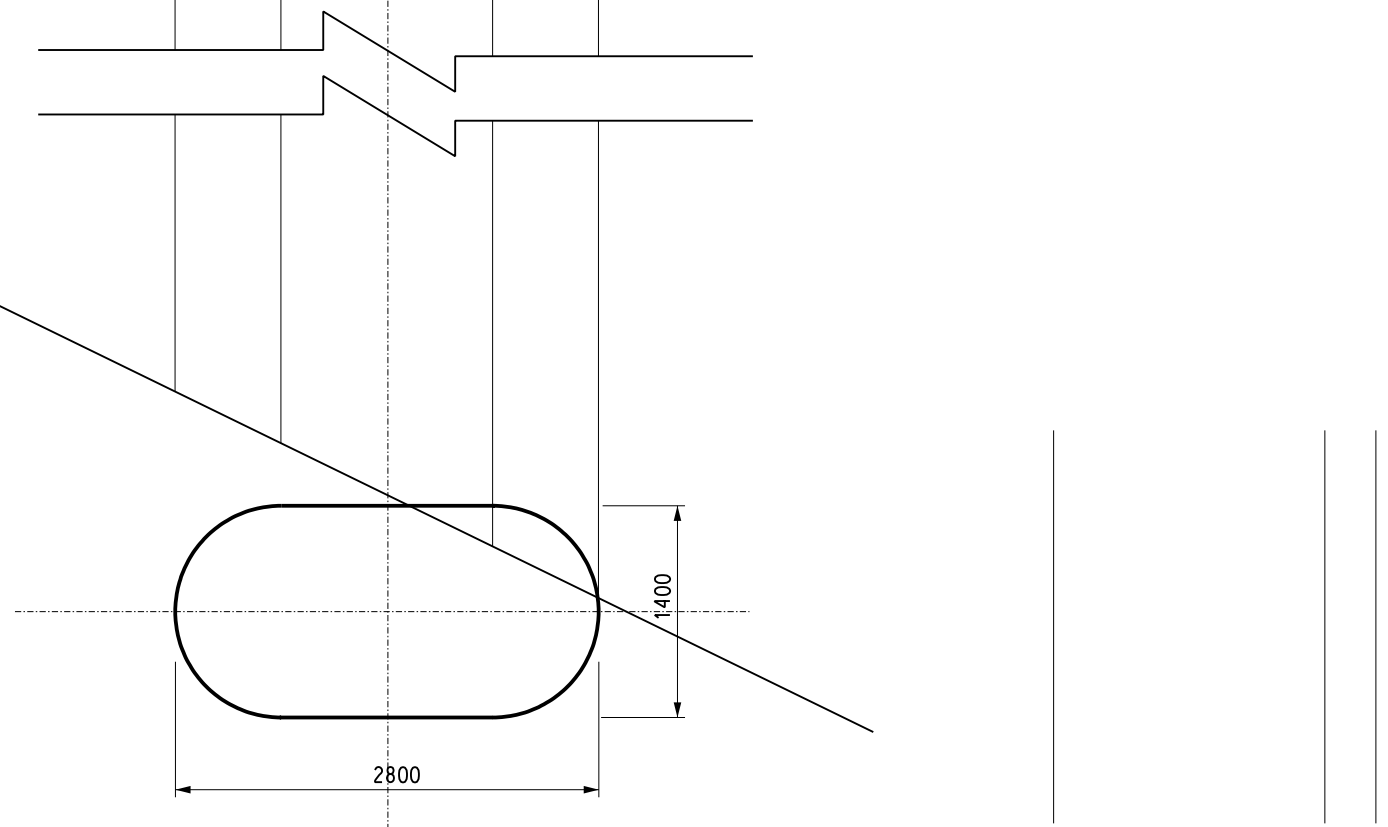

CAD FILE: 90803/SEC1.DWG

BRIDGE DECK - TYPICAL CROSS SECTION